

Pan head screw sems with
spring lock washer and flat washer
according to JIS B1188

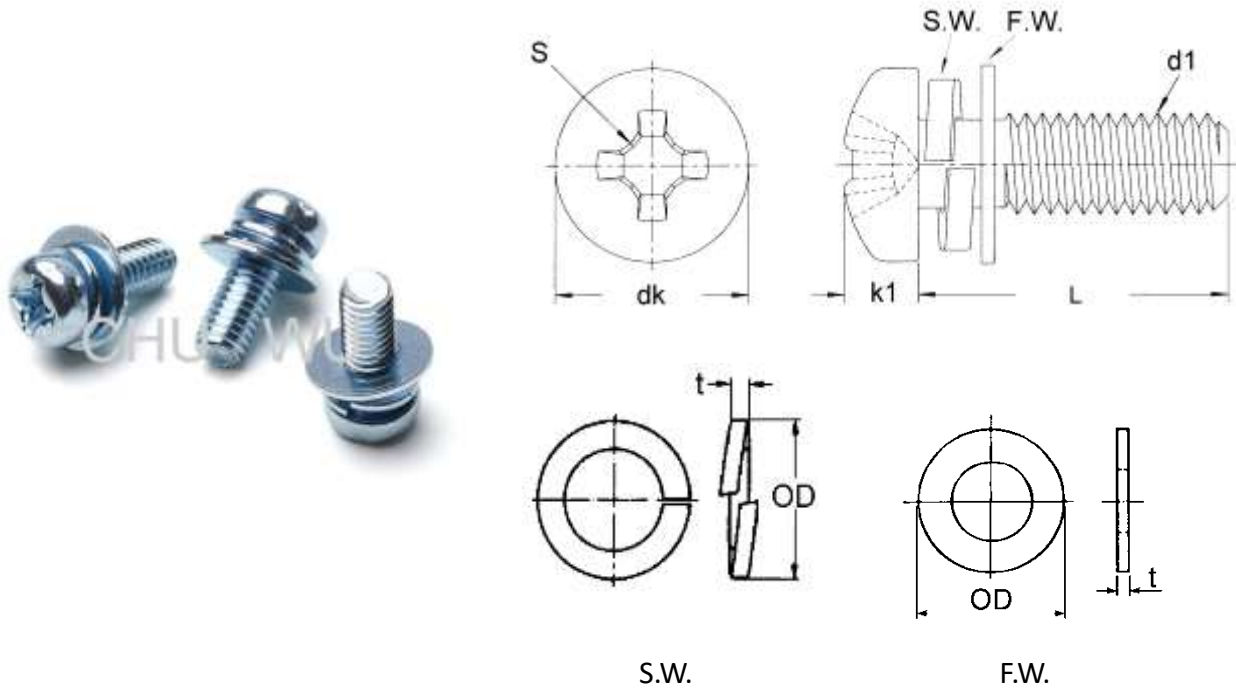

Unit : mm

Thread size (d1)	Pitch (P)	Head diameter (dk)	Head height (k1)	Driver Size (S)	S.W		F.W	
					(OD)	(t)	(OD)	(t)
M2	0.4	3.5	1.3	NO.1	4	0.5	4.3	0.3
M2.5	0.45	4.5	1.7	NO.1	4.8	0.6	5	0.5
M3	0.5	5.5	2	NO.2	5.5	0.7	6	0.5
M4	0.7	7	2.6	NO.2	7	1	8	0.8
M5	0.8	9	3.3	NO.2	8.5	1.3	10	1.0
M6	1.0	10.5	3.9	NO.3	11.5	1.5	11.5	1.6
M8	1.25	14	5.2	NO.3	14.5	2	15.5	1.6



CHU WU INDUSTRIAL CO., LTD.

No. 16, Guanghua Rd., Sanchong Dist., New Taipei City 241, Taiwan
Tel: +886-2-8512-4735(Rep.) Fax: +886-2-8512-4295, 8512-4737
E-mail: sales@chuwu.com.tw http://www.chuwu.com.tw