

# Inch Fastener

## Pan head screw sems with spring lock washer and flat washer

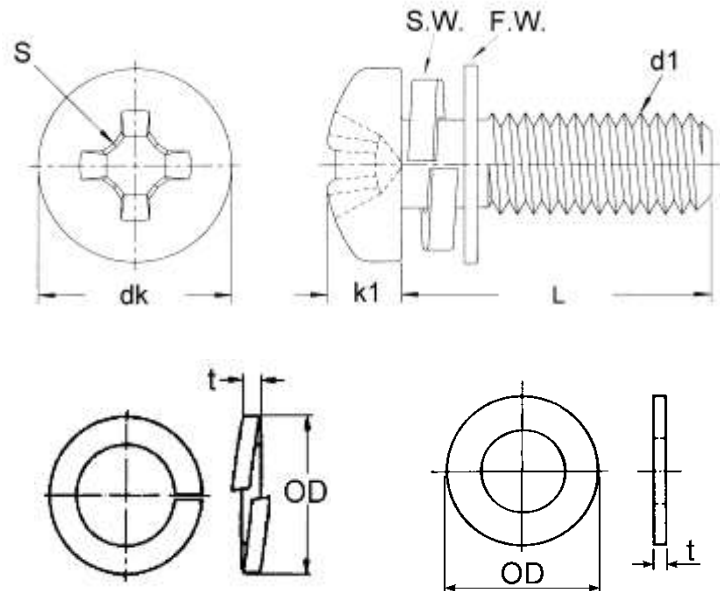

S.W.

F.W.

Unit : inch

Thread size (d1)	Head diameter (dk)	Head height (k1)	Driver size (S)	S.W		F.W	
				(OD)	(t)	(OD)	(t)
#2-56	0.167	0.062	NO.1	0.156	0.020	0.250	0.032
#4-40	0.219	0.080	NO.1	0.208	0.031	0.383	0.040
#6-32	0.270	0.097	NO.2	0.261	0.034	0.446	0.040
#8-32	0.322	0.115	NO.2	0.319	0.031	0.508	0.040
#10-24or32	0.373	0.133	NO.2	0.373	0.047	0.570	0.040

Screw standard according to ASME B18.6.3

Washer standard according to ASME B18.13



**CHU WU INDUSTRIAL CO., LTD.**

No. 16, Guanghua Rd., Sanchong Dist., New Taipei City 241, Taiwan  
 Tel: +886-2-8512-4735(Rep.) Fax: +886-2-8512-4295, 8512-4737  
 E-mail: sales@chuwu.com.tw http://www.chuwu.com.tw