

ISO7380-2 Hexalobular button head screw with collar

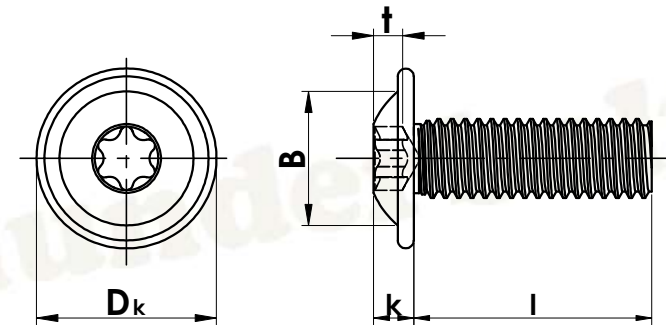

Nom. dia.	Pitch	Collar diameter (D _k)(max.)	Head height (D _k)(max.)	Recess (A)	Crown diameter (B)(ref.)	Penetration gauging depth (t)(min.)
M8	1.25	13.00	13.27	8.00	No.40	2.40
M6	1.00	10.00	10.22	6.00	No.30	1.80
M5	0.80	8.50	8.72	5.00	No.25	1.60
M4	0.70	7.00	7.22	4.00	No.20	1.25
M3	0.50	5.50	5.68	3.00	No.10	0.95
M2.5	0.45	For more information, please contact our sales staff				
M2	0.40					
M1.6	0.35					
M1.4	0.30					

Unit: mm