

ISO14579 Hexalobular socket head cap screw

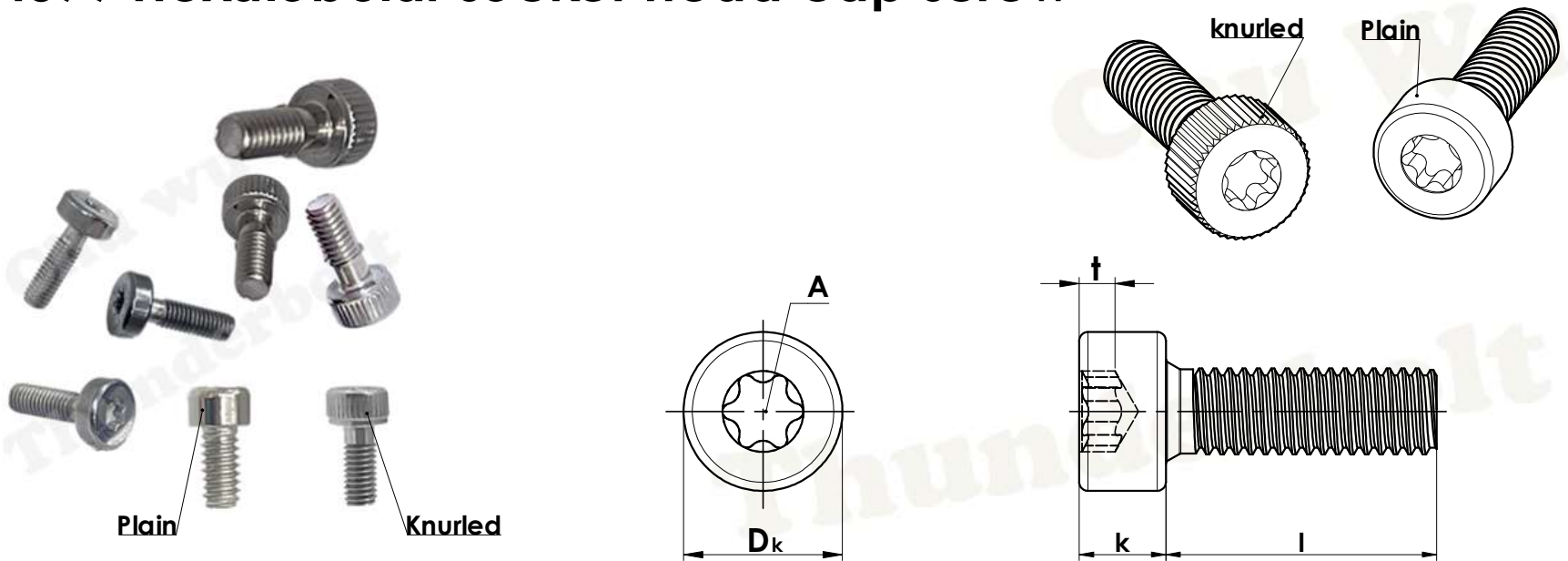

Nom. dia.	Pitch	Head diameter (plain)(D_k)(max.)	Head diameter (knurled)(D_k)(max.)	Head height (k) (max.)	Recess (A)	Penetration gauging depth (t) (min.)
M8	1.25	13.00	13.27	8.00	No.45	2.92
M6	1.00	10.00	10.22	6.00	No.30	2.02
M5	0.80	8.50	8.72	5.00	No.25	1.65
M4	0.70	7.00	7.22	4.00	No.20	1.42
M3	0.50	5.50	5.68	3.00	No.10	1.01
M2.5	0.45	4.50	4.68	2.50	No.8	0.91
M2	0.40	3.80	3.98	2.00	No.6	0.71
M1.6	0.35	For more information, please contact our sales staff				
M1.4	0.30					
M1	0.25					

Unit: mm