

ISO14585 Hexalobular socket pan head tapping screw type F

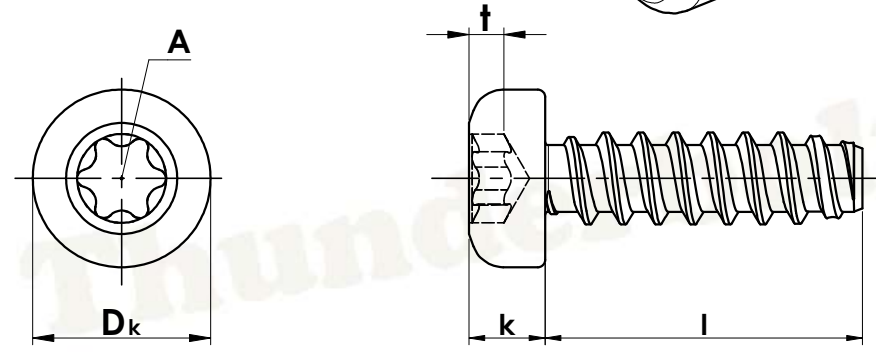
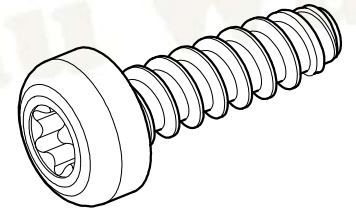

Nom. dia.	Pitch (≈) (P)	Head diameter (D _k) (max.)	Head height (k) (max.)	Recess (A)	Penetration gauging depth (t) (min.)
ST6.3	1.80	12.00	4.60	No.30	2.02
ST5.5	1.80	11.00	4.00	No.25	1.65
ST4.8	1.60	9.50	3.70	No.25	1.65
ST4.2	1.40	8.00	3.10	No.20	1.42
ST3.5	1.30	7.00	2.60	No.15	1.14
ST2.9	1.10	5.60	2.40	No.10	1.01
ST2.6	0.90	For more information, please contact our sales staff			
ST2.2	0.80				
ST1.9	0.60				
ST1.5	0.50				

Unit: mm