

ISO14583 Hexalobular socket pan head screw

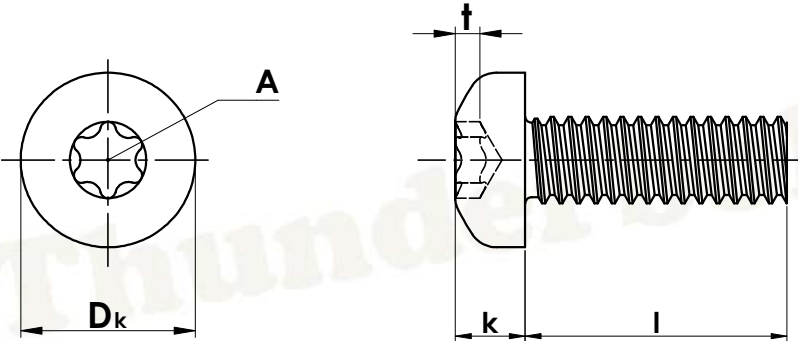
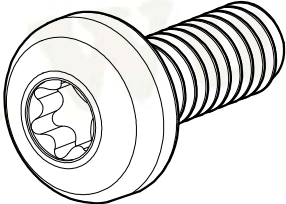

Nom. dia.	Pitch (P)	Head diameter (D _k) (max.)	Head height (k) (max.)	Recess (A)	Penetration gauging depth (t) (min.)
M8	1.25	16.00	6.00	No.45	2.79
M6	1.00	12.00	4.60	No.30	2.02
M5	0.80	9.50	3.70	No.25	1.52
M4	0.70	8.00	3.10	No.20	1.27
M3	0.50	5.60	2.40	No.10	1.01
M2.5	0.45	5.00	2.10	No.8	0.91
M2	0.4	4.00	1.60	No.6	0.63
M1.6	0.35	For more information, please contact our sales staff			
M1.4	0.3				
M1.2	0.25				
M1	0.25				

Unit: mm