

# ASME B18.6.3-Hexalobular recess flat head screw

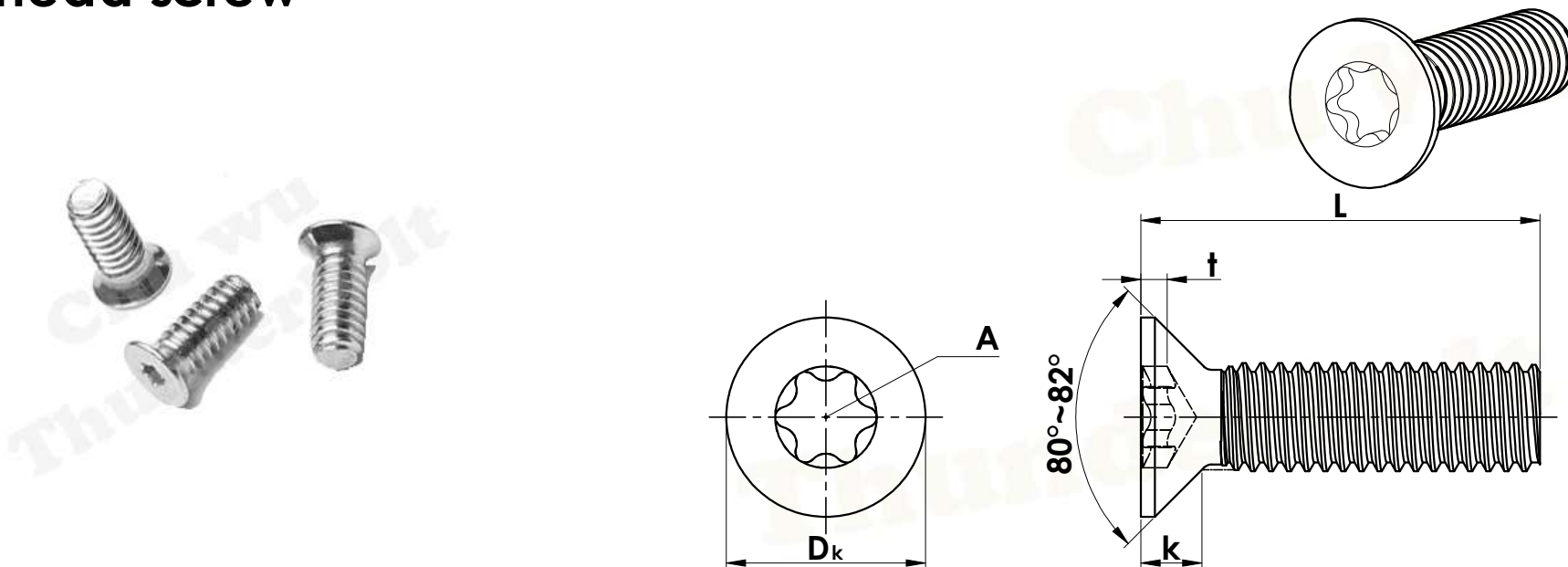

Nom. dia.	Head diameter (D <sub>k</sub> ) (max.)	Head height (k) (ref.)	Recess (A)	Penetration gauging depth (t) (min.)
# 10-32	0.362	0.116	T20	0.050
# 8-32	0.312	0.100	T15	0.040
# 6-32	0.262	0.083	T10	0.035
# 5-40	0.237	0.075	T10	0.035
# 4-40	0.212	0.067	T8	0.028
# 3-48	0.187	0.059	T8	0.020
# 2-56	0.162	0.051	T6	0.017
# 1-64	For more information, please contact our sales staff			
# 0-80				
# 00-90				

Unit: inch